



## ***Dry Age Cabinet***

Model DA-CN-0480

Item 46689

## ***Instruction Manual***



*Revised - 06/17/2024*



---

Toll Free: 1-800-465-0234  
Fax: 905-607-0234  
Email: [service@omcan.com](mailto:service@omcan.com)  
[www.omcan.com](http://www.omcan.com)



# ***Table of Contents***

Model DA-CN-0480

---

<b>Section</b>	<b>Page</b>
Disclaimer -----	3
General Information -----	4 - 5
Safety and Warranty -----	5 - 8
Technical Specifications -----	9
Operation -----	9 - 11
Maintenance -----	12
Troubleshooting -----	12 - 13
Parts Breakdown -----	14 - 17
Electrical Schematics -----	18
Warranty Registration -----	19

## **Disclaimer**

---

*OMCAN IS NOT RESPONSIBLE FOR ANY DAMAGES DUE TO WATER LEAKS. WARRANTY FOR WATER LEAKS IS VOID IF THE WICKING PAD IS NOT REPLACED EVERY SIX MONTHS, AND IF THE AMBIENT ROOM TEMPERATURE EXCEEDS 75°F AND 55% RELATIVE HUMIDITY, AND THE APPLIANCE DRAIN IS NOT CONNECTED DIRECTLY TO THE FLOOR DRAIN.*

---

*OMCAN N'EST PAS RESPONSABLE DES DOMMAGES DUS AUX FUITES D'EAU. LA GARANTIE POUR LES FUITES D'EAU EST ANNULÉE SI LE TAMPON ABSORBANT N'EST PAS REMPLACÉ TOUS LES SIX MOIS, ET SI LA TEMPÉRATURE AMBIANTE DE LA PIÈCE DÉPASSE 75°F ET 55% D'HUMIDITÉ RELATIVE, ET QUE LE DRAIN DE L'APPAREIL N'EST PAS RACCORDÉ DIRECTEMENT AU DRAIN DE PLANCHER.*

---

*OMCAN NO SE HACE RESPONSABLE DE LOS DAÑOS CAUSADOS POR FUGAS DE AGUA. LA GARANTÍA POR FUGAS DE AGUA QUEDA ANULADA SI LA ALMOHADILLA ABSORBENTE NO SE REEMPLAZA CADA SEIS MESES, Y SI LA TEMPERATURA AMBIENTE SUPERA LOS 75°F Y EL 55% DE HUMEDAD RELATIVA, Y EL DESAGÜE DEL APARATO NO ESTÁ CONECTADO DIRECTAMENTE AL DESAGÜE DEL PISO.*

## ***General Information***

---

**Omcan Manufacturing and Distributing Company Inc., Food Machinery of America, Inc. dba Omcan and Omcan Inc. are not responsible for any harm or injury caused due to any person's improper or negligent use of this equipment. The product shall only be operated by someone over the age of 18, of sound mind, and not under the influence of any drugs or alcohol, who has been trained in the correct operation of this machine, and is wearing authorized, proper safety clothing. Any modification to the machine voids any warranty, and may cause harm to individuals using the machine or in the vicinity of the machine while in operation.**

### **CHECK PACKAGE UPON ARRIVAL**

Upon receipt of an Omcan shipment please inspect for external damage. If no damage is evident on the external packaging, open carton to ensure all ordered items are within the box, and there is no concealed damage to the machine. If the package has suffered rough handling, bumps or damage (visible or concealed), please note it on the bill of lading before accepting the delivery and contact Omcan within 24 hours, so we may initiate a claim with the carrier. A detailed report on the extent of the damage caused to the machine must be filled out within three days, from the delivery date shown in the shipping documents. Omcan has no recourse for damaged products that were shipped collect or third party.

**Before operating any equipment, always read and familiarize yourself with all operation and safety instructions.**

**Omcan would like to thank you for purchasing this machine. It's of the utmost importance to save these instructions for future reference. Also save the original box and packaging for shipping the equipment if servicing or returning of the machine is required.**

---

**Omcan Fabrication et distribution Compagnie Limité et Food Machinery d'Amérique, dba Omcan et Omcan Inc. ne sont pas responsables de tout dommage ou blessure causé du fait que toute personne ait utilisé cet équipement de façon irrégulière. Le produit ne doit être exploité que par quelqu'un de plus de 18 ans, sain d'esprit, et pas sous l'influence d'une drogue ou d'alcool, qui a été formé pour utiliser cette machine correctement, et est vêtu de vêtements de sécurité appropriés. Toute modification de la machine annule toute garantie, et peut causer un préjudice à des personnes utilisant la machine ou des personnes à proximité de la machine pendant son fonctionnement.**

### **VÉRIFIEZ LE COLIS DÈS RÉCEPTION**

Dès réception d'une expédition d'Omcan veuillez inspecter pour dommages externes. Si aucun dommage n'est visible sur l'emballage externe, ouvrez le carton afin de s'assurer que tous les éléments commandés sont dans la boîte, et il n'y a aucun dommage dissimulé à la machine. Si le colis n'a subi aucune mauvaises manipulations, de bosses ou de dommages (visible ou cachée), notez-le sur le bond de livraison avant d'accepter la livraison et contactez Omcan dans les 24 heures qui suivent, pour que nous puissions engager une réclamation auprès du transporteur. Un rapport détaillé sur l'étendue des dommages causés à la machine doit être rempli dans un délai de trois jours, à compter de la date de livraison indiquée dans les documents d'expédition. Omcan n'a aucun droit de recours pour les produits endommagés qui ont été expédiés ou cueillis par un tiers transporteur.

**Avant d'utiliser n'importe quel équipement, toujours lire et vous familiariser avec toutes les opérations et les**

## General Information

consignes de sécurité.

Omcan voudrais vous remercier d'avoir choisi cette machine. Il est primordial de conserver ces instructions pour une référence ultérieure. Également conservez la boîte originale et l'emballage pour l'expédition de l'équipement si l'entretien ou le retour de la machine est nécessaire.

Omcan Empresa De Fabricacion Y Distribucion Inc. Y Maquinaria De Alimentos De America, Inc. dba Omcan y Omcan Inc. no son responsables de ningun daño o perjuicio causado por cualquier persona inadecuada o el uso descuidado de este equipo. El producto solo podra ser operado por una persona mayor de 18 años, en su sano juicio y no bajo alguna influencia de droga o alcohol, y que este ha sido entrenado en el correcto funcionamiento de esta máquina, y ésta usando ropa apropiada y autorizada. Cualquier modificación a la máquina anula la garantía y puede causar daños a las personas usando la máquina mientras esta en el funcionamiento.

### REVISE EL PAQUETE A SU LLEGADA

Tras la recepcion de un envio Omcan favor inspeccionar daños externos. Si no hay daños evidentes en el empaque exterior, Habra el carton para asegurarse que todos los articulos solicitados estén dentro de la caja y no encuentre daños ocultos en la máquina. Si el paquete ha sufrido un manejo de poco cuidado, golpes o daños (visible o oculto) por favor anote en la factura antes de aceptar la entrega y contacte Omcan dentro de las 24 horas, de modo que podamos iniciar una reclamación con la compañía. Un informe detallado sobre los daños causados a la máquina debe ser llenado en el plazo de tres días, desde la fecha de entrega que se muestra en los documentos de envío. Omcan no tiene ningun recurso por productos dañados que se enviaron a recoger por terceros.

Antes de utilizar cualquier equipo, siempre lea y familiarizarse con todas las instrucciones de funcionamiento y seguridad.

Omcan le gustaría darle las gracias por la compra de esta máquina. Es de la mayor importancia para salvar estas instrucciones para futuras consultas. Además, guarda la caja original y el embalaje para el envío del equipo si servicio técnico o devolución de la máquina que se requiere.

## Safety and Warranty

### HANDLE AND ASSEMBLING



#### Handle with care

Unplug wall socket before moving. Never tilt the refrigerator over 45 degrees during handling.



#### Storage

Always store refrigerator in a dry place.

# Safety and Warranty

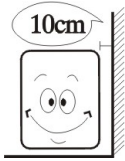

### Sufficient space

To allow for proper air circulation and increased refrigeration capabilities, the refrigerator must have at least 3 inches of space between wall and unit.

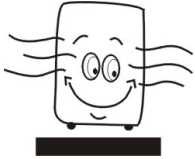

### Proper ventilation

Always place the refrigerator in an area with good ventilation. For first time use, wait at least 2 hours before plugging into wall socket.



### X Away from heat source

Never place the refrigerator near any type of heat source or in direct sunlight, as it reduces refrigeration capabilities.



### X No heavy load

Never put heavy items on top of the refrigerator.



### No alterations/tampering

Never tamper with, or make changes to the refrigerator. Changes and add-ons should not be installed to the inside or outside of the refrigerator.

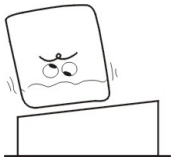

### Stable location

Unpack and place the refrigerator on flat, solid ground.

## PREPARATION AND POWER SUPPLY

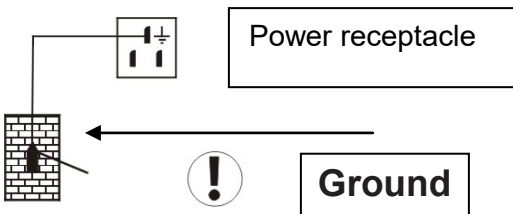

### Exclusive power socket

Power supply should be 110-120V, single phase AC with exclusive single phase three pin outlet and fuse (8A). The power outlet must be in close proximity to the ground.

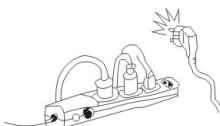

### No shared power outlets

Refrigerator cable should never share the power outlet with any other appliance, as cable will overheat and may result in a fire.

## Safety and Warranty

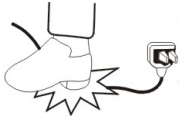

### Protect cables

Extra caution should be used when handling cables, as broken or damaged cables can cause sparking and may result in a fire.



### No water flushing

Never flush the refrigerator surface. This can cause leakage, which may result in electrical damage or fire.



### Never store flammables and explosives

No explosives or flammables should be stored in, or in proximity to, the refrigerator, such as gasoline, alcohol, and adhesives.

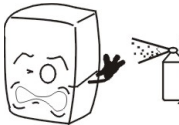

### No spray

Never spray flammables such as paint or coating near the refrigerator. This may cause fire or malfunction.



### After power outage

After a power outage or the unplugging of the refrigerator, wait at least 5 minutes before plugging it back in.



### No medicine

Medicine should not be stored inside of the refrigerator.

## CAUTIONS

Shorten the door open time and reduce open frequency is good to keep a cold temperature inside the refrigerator. Never block the air suction and outlet. Keep air circulation and refrigeration capability. Do not make food congested as it will influence the cooling effect. Adjust the rack height for proper food storage. Cool the hot food down to room temperature before you put it into the refrigerator. Try to reduce the open times and keep refrigerator inside cold in case the power is cut off. Only skilled service man is allowed to repair the damaged power cable with special tools. Never touch compressor to avoid from scald. This appliance is not intended for use by persons (including children) with reduced physical, sensory or mental capabilities, or lack of experience and knowledge, unless they have been given supervision or instruction concerning use of the appliance by a person responsible for their safety. Children should be supervised to ensure that they do not play with the appliance. The operation manual are not suitable for the persons (including children) with reduced physical, sensory or mental capabilities, or lack of experience and knowledge. Do not store explosive substances such as aerosol cans with a flammable propellant in this appliance. During normal operation, the emission noise level does not exceed 70dB(A) The maximum loading of the shelf does not exceed 18kg. The climatic class of the appliance is 4, the units are suggested to be used at 16 - 32 ambient temperature. To avoid damages or other problems, this product can not be put or stored with any corrosive food. Avoid placing

## ***Safety and Warranty***

---

appliances in direct sunlight or near cookers, radiators, or similar sources of heat. The energy consumption depends on the environment (i.e. ambient temperature). Dust accumulation increases energy consumption, at least once a year, use a vacuum cleaner to clean the condenser on the back of the product. When transporting or using products above 1500 meters above sea level, the insulating glass on the door may break due to the decrease of atmospheric pressure. The edge of the fragment is sharp, which can cause serious injury.

**RESIDENTIAL USERS: vendor assumes no liability for parts or labor coverage for component failure or other damages resulting from installation in non-commercial or residential applications. The right is reserved to deny shipment for residential usage; if this occurs, you will be notified as soon as possible.**

### **1 YEAR PARTS AND LABOUR WARRANTY**

Within the warranty period, contact Omcan Inc. at 1-800-465-0234 to schedule an Omcan authorized service technician to repair the equipment locally.

Unauthorized maintenance will void the warranty. Warranty covers electrical and part failures, not improper use.

Please see <https://omcan.com/disclaimer> for complete info.

### **WARNING:**

The packaging components are classified as normal solid urban waste and can therefore be disposed of without difficulty.

In any case, for suitable recycling, we suggest disposing of the products separately (differentiated waste) according to the current norms.

**DO NOT DISCARD ANY PACKAGING MATERIALS IN THE ENVIRONMENT!**



# Technical Specifications

<b>Model</b>	DA-CN-0480
<b>Item Number</b>	46689
<b>Net Volume</b>	480 L / 16.95 cu.ft.
<b>Power</b>	200 W
<b>Electrical</b>	110-120V / 60Hz / 1
<b>Current</b>	1.8A
<b>Temperature Range</b>	0 - 25°C / 32 - 77°F
<b>Max Ambient Temp Rating</b>	24°C / 75°F
<b>Refrigerant</b>	R290 (55g)
<b>Lamp Power</b>	10 W
<b>Humidity Range</b>	30 - 90%
<b>Type of Climate</b>	4
<b>Protection Mode</b>	I
<b>Foaming Agent</b>	Cyclopentane
<b>Net Dimensions (DWH)</b>	27.6" x 31.9" x 65.4" / 700 x 810 x 1662mm
<b>Net Weight</b>	269 lbs. / 122 kgs.

## Operation

1. This product is a dry-aging cabinet with fully enclosed compressor. The refrigerant R290 is of an environmentally friendly agent. It features a rational configuration of refrigeration system with blowing forced air cooling. The temperature is quite even inside the refrigerator.
2. The product adopts the stainless steel shell foaming box body. It features an artistic and elegant appearance with good heat preservation effect. The door adopts double hollow glass, which has perfect perspective.
3. This product is suitable for refrigerated storage of meat or food in residential, commercial places, etc.

### BEFORE USE:









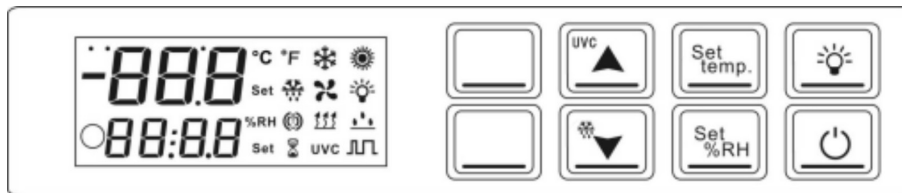

1. Clean the inside of the product with a mild disinfectant.
2. Plug in the device in a 110-120V socket.
3. The temperature and humidity are already set on 1.5 and 82% humidity which are the perfect setting for dry aging beef and pork.
4. The meat for dry aging must be fresh, perfect would be max. 5 days after slaughtering. Even vacuum matured meat can be used, but for a maximum of 14 days (please remove the packaged foil).

# Operation

5. Open the food package and remove the foil. Put the meat on the stainless steel plate and put the plate inside the device. Check whether there is water in the plate every 2-3 days. If there is any water, please clear the water.
6. The maximum load capacity of shelves is 20KG individual pieces. Optional hooks and support racks are available for hanging steak with a length of 19.7" - 35.4".
7. Please wear protective gloves when contacting with meat every time. No one should ever touch the meat without gloves.
8. The perfect maturing time is between 25-28 days, but more than 4 weeks is also possible.

## DIGITAL TEMPERATURE CONTROLLER





LED/SYMBOL	MODE	FUNCTION
	ON	COOLING
	FLASHING	Delay Cool
	ON	Light working
	ON	Fans running
	ON	Heating active
	ON	Acoustic Alarm
	ON	Dehumidification
	ON	Humidification
	ON	Defrost Active
	FLASHING	Defrost
UVC	ON	UVC-Desinfection active
UVC	FLASHING	UVC alarm

## OPERATING AND CONTROL SETTINGS

: Power ON/OFF

: LED lights on and off.

: View / change the temperature settings.



: View / change humidity settings / select or confirm parameter settings.

: Short press to increase temperature and humidity setting / long press UVC to turn on and off.





: Short press to reduce temperature and humidity setting / long press to defrost manually.

## CONTROLLER OPERATING INSTRUCTIONS





### 1. Power on and off operation:

Press the button  once for 5 seconds and the OFF symbol is displayed. After 5 seconds, the compressor is turned off. All relays are deactivated, only the indicator light is on. Press the  key to start the system directly and enter normal operation mode; in the standby state, pressing other keys except  key is invalid.



### 2. Key lock / unlock operation:

In the power on state, press  and  and hold together, for a minimum of 3 seconds, POF appears for a few seconds. (POF=OFF parameter). After the key is locked, the POF character will be displayed for all operations except the  key and "UVC" key function. In the locked state, press  and  at the same time. After 3 seconds, the humidity area flashes and displays "PON" for 3 seconds, indicating that it is unlocked.



### 3. Temperature setting operation:

In the power on state, press the  key briefly to enter the temperature setting state. The temperature setting value and "SET" icon flash, press the  or  key to change the temperature setting value, release the key without pressing or pressing the  key within 1 minute, exit the temperature setting, save the setting value and return to the normal power on state.

### 4. Manual defrosting operation:

In the normal power on state, hold down the button  for a min 2 seconds. it will enter the manual defrosting mode, and the  icon will be on. After entering the defrosting mode, if the defrosting exit condition is met, it will exit the defrosting mode directly. Under the working state of defrosting, press the  key once to exit defrosting directly and return to normal working condition.

### 5. UVC on/off operation instructions:

Under normal start-up state, press  for at least 5 seconds, start UVC ultraviolet disinfection. The "UVC" indicator is on, which represents disinfection work. When UVC ultraviolet disinfection lamp is on, press  for at least 5 sec, and turn off UVC disinfection lamp.

### 6. One key reset operation:

In the normal power on state, press  and  keys at the same time, and the buzzer will sound for a long time after 3 seconds, indicating that all parameters are restored to factory set value.

# Maintenance

---

**NOTICE:**

Always keeping the refrigerator clean and maintaining periodically is necessary. Always unplug the socket before maintenance. Never use damaged plug or loose socket to prevent from electric shock or short circuit. Never flush the refrigerator with water. Never use alkali detergent, soap, gasoline, acetone or brush.

**CLEAN OUTSIDE:**

Dip soft cloth in neutral detergent (table ware detergent) to clean the outside of the refrigerator and then wipe it with dry soft cloth.

**CLEAN INSIDE:**

Take rack out for cleaning with water.

**SHUT DOWN REFRIGERATOR FOR A LONG TIME:**

Take all food out and unplug the wall socket. Clean both inside and outside of the refrigerator thoroughly and open the door for sufficient dry. The glass breaks easily. Keep the glass far from children. Clean the condensate tray and wipe it dry.

# Troubleshooting

---

Trouble	Cause and Remedy
No refrigeration.	Is the plug securely in the socket?
	Is the fuse broken?
	Is there no power?
Poor refrigeration.	Is it under sunlight? Is there any heat source nearby?
	Is the surrounding ventilation poor?
	Does the door close properly? Does the door stay open for a long period of time?
	Is the door seal strip deformed or damaged?
	Is the food congested or is there too much food?
	Does food block the air suction or outlet?
	Regulate the temperature controller.
Noisy.	The refrigerator is not level.
	The refrigerator is making contact with the wall or other objects.
	There is a loose part in the refrigerator.
Contact Omcan for help if simple trouble shooting does not solve the problems.	

# Troubleshooting

## NOTE

### Following occurrences are not problems:

- The murmur of water is heard when the refrigerator is working. It is a normal occurrence as the coolant is circulating in the system.
- When the weather is damp, condensation might be found on the outside of the refrigerator. It is caused by high humidity. Simply use cloth to wipe it off.

## ALARMS

Error code	Reason for Error code	Alarm reset
P1	Temperature probe failure.	After the probe returns to normal, the alarm will stop automatically.
P2	Defrost probe failure.	
P3	Humidity probe failure.	
HA	High temperature alarm.	When the temperature returns to the normal value (correction of return difference) or defrosting is started, the alarm will stop automatically.
LA	Low temperature alarm.	
HHA	High humidity alarm.	When the humidity returns to the normal value (correction of return difference), the alarm will stop automatically.
HLA	Low humidity alarm.	
dA	Door switch alarm.	The alarm stops automatically after closing the door.

The alarm message will be displayed all the time until the alarm is reset. Once the buzzer alarm is detected, press the power key to eliminate the buzzer (mute).

# Parts Breakdown

**Model DA-CN-0480** 46689

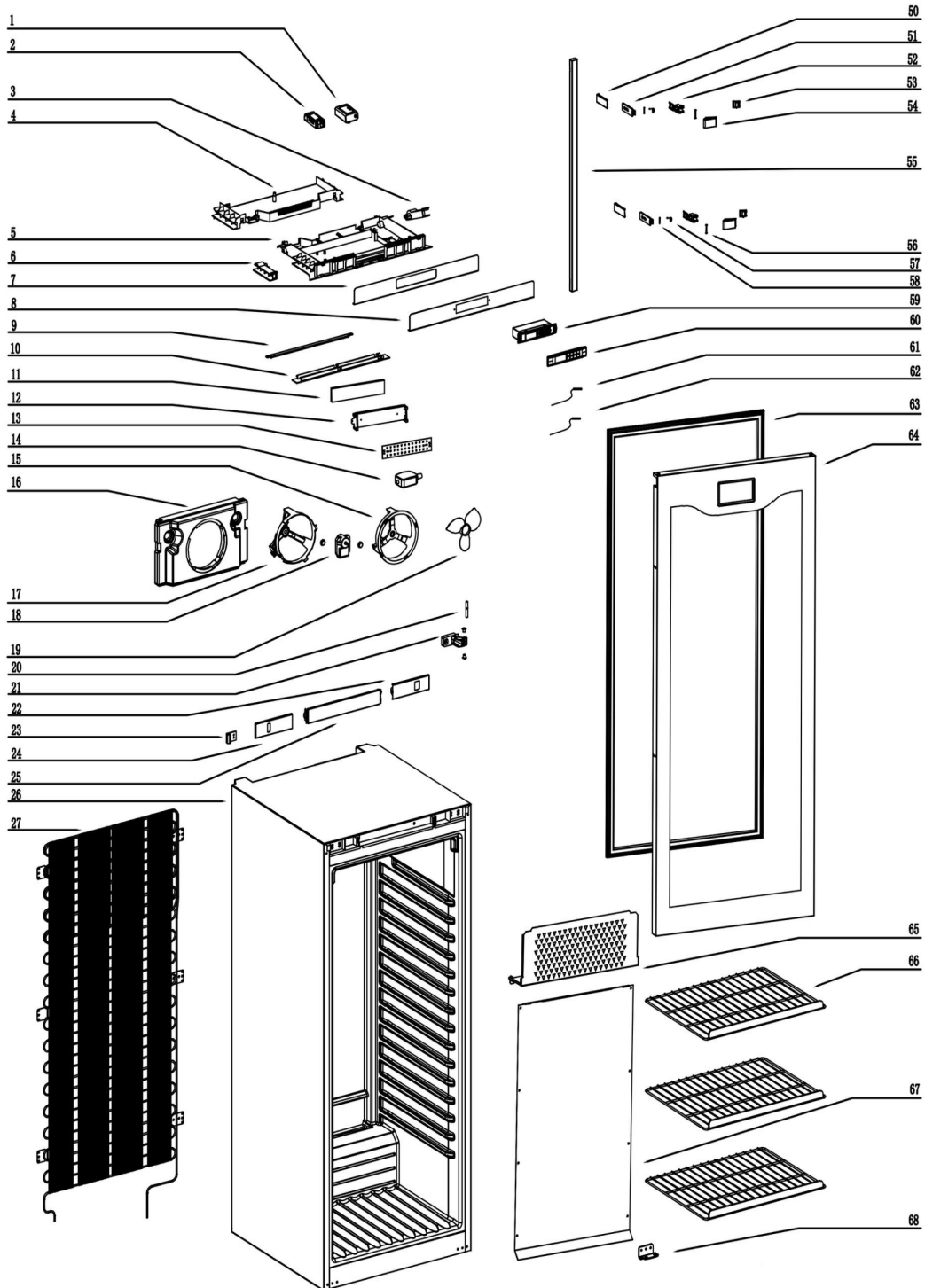

# Parts Breakdown

**Model DA-CN-0480** 46689

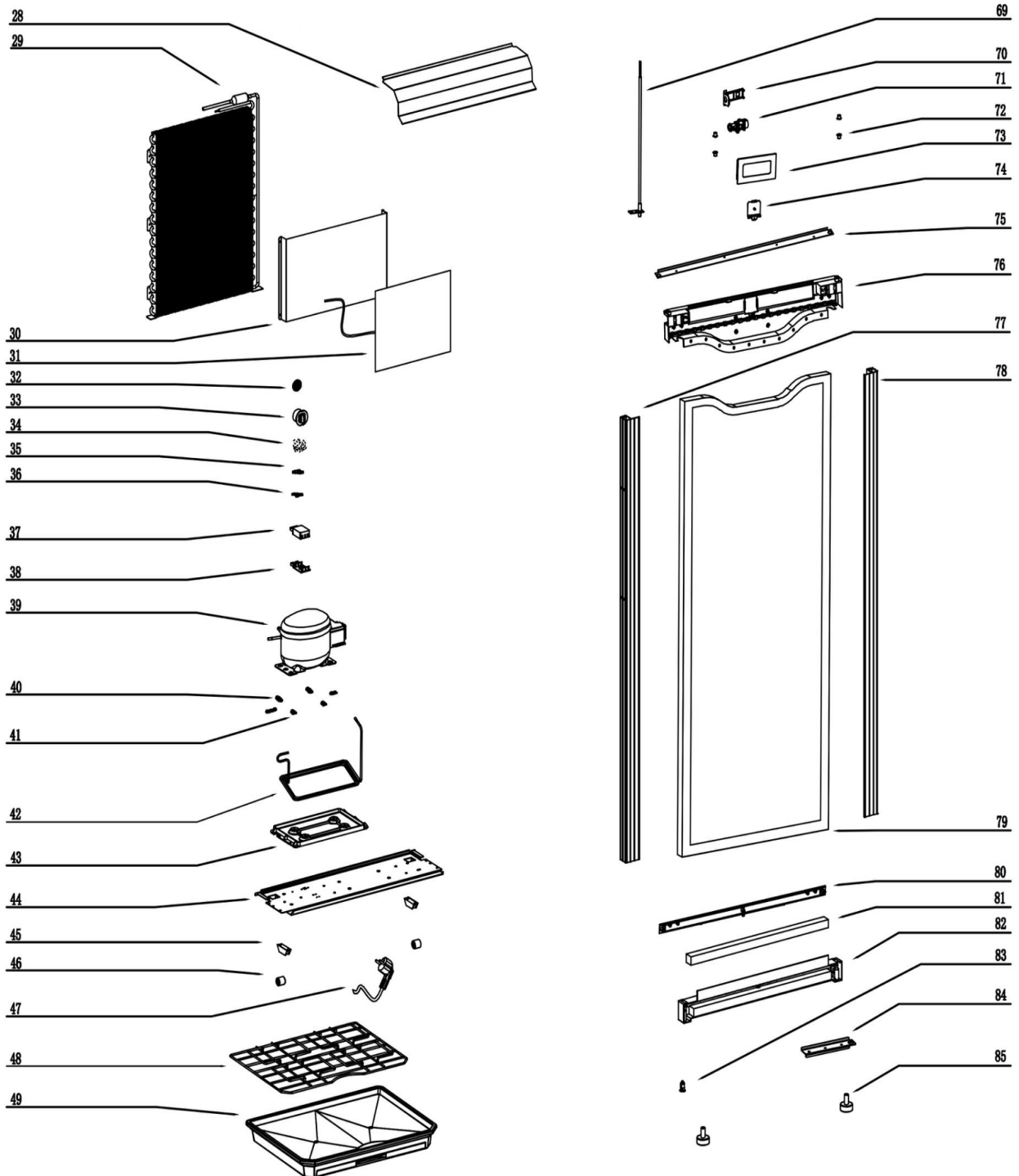

# Parts Breakdown

## Model DA-CN-0480 46689

Item No.	Description	Position	Item No.	Description	Position	Item No.	Description	Position
AQ506	Switching Power Supply for 46689	1	AQ529	Magnetron Probe Fixing Plate Spray Paint for 46689	25	AQ548	Door Handles-Guide Rail Spray Paint for 46689	51
67683	LED Transformer for 46689	2	AQ530	Box-Foaming for 46689	26	AQ549	Door Handles-Spring Bottom Seat for 46689	52
AQ507	Right Bracket of Temperature Control Plate for 46689	3	AQ531	Condenser for 46689	27	AQ550	Door Handle-Base Cover Plate Spray Paint for 46689	53
AQ508	Top Ventilation Disc for 46689	4	AQ532	Flow Guide Plate for 46689	28	AQ551	Door Handle-Base Spray Paint for 46689	54
AQ509	Top Temperature Control Plate for 46689	5	AQ533	Evaporator for 46689	29	AQ552	Shake Hands for 46689	55
AQ510	Left Bracket of Temperature Control Panel for 46689	6	AQ534	Heating Film Fixing Plate for 46689	30	AQ553	Flat-Headed Mother Rivets for 46689	56
AQ511	Left Bracket of Temperature Control Panel for 46689	7	AQ535	Aluminum Foil Heater for 46689	31	AQ554	Spring for 46689	57
AQ512	Thermostat Decorative Board for 46689	8	AQ536	Activated Carbon Plug for 46689	32	AQ555	Positioning Pin for 46689	58
AQ513	Patch LED Lamp for 46689	9	AQ537	Activated Carbon Knob for 46689	33	AQ556	Thermostat for 46689	59
AQ514	Transparent Light Board for 46689	10	61245	Wire Clamp Cover for 46689	35	AQ557	Temperature-Controlled Cover for 46689	60
AQ515	Photocatalyst for 46689	11	61246	Wire Clip Holder for 46689	36	AQ558	Room Temperature Sensor for 46689	61
AQ516	Photocatalyst Fixture for 46689	12	79359	Cover of Junction Box for 46689	37	67674	Compressor Protect Probe for 46689	62
AQ517	Constant Pressure Patch LED Lamp-Ultraviolet for 46689	13	61244	Terminal Box for 46689	38	AQ559	Door Seal for 46689	63
AQ518	Temperature and Humidity Sensor for 46689	14	AH719	Compressor for 46689	39	AQ560	Door Decoration Panel for 46689	64
AQ519	On the Fixed Ring of the Motor for 46689	15	AQ538	High-Pressure Evaporator Pressure Plate-3 Holes for 46689	40	AQ561	On the Cover of the Evaporator for 46689	65
AQ520	Evaporator Motor Foam for 46689	16	AQ539	High-Pressure Evaporator Pressure Plate-2 Holes for 46689	41	AQ562	Net Rack for 46689	66
AQ521	Under the Motor Fixing Ring for 46689	17	AQ540	High-Pressure Evaporation Tube for 46689	42	AQ563	Under the Cover of the Evaporator for 46689	67
AQ522	Electric Machinery for 46689	18	AQ541	Water Supply Box for 46689	43	AQ564	Lower Door Shaft Fixing Plate for 46689	68
AQ523	Wind and Leaf for 46689	19	AQ542	The Bottom Plate for 46689	44	AQ565	Torsion Bar for 46689	69
AQ524	Door-to-Door Sales for 46689	20	AQ543	Bottom Foot for 46689	45	AQ566	Door Lock Cover, Spray Paint for 46689	70
AQ525	Upper Hinge-Oxidation for 46689	21	AQ544	Pulley for 46689	46	AQ567	Door Lock for 46689	71
AQ526	Door-to-Door Shaft Decorative Panel, Spray Paint for 46689	22	AQ545	Semi-Finished Power Cord for 46689	47	AQ568	Door-to-Door Shaft Sleeve for 46689	72
AQ527	Door Lock Fixing Plate for 46689	23	AQ546	Salt Rock Mesh Rack for 46689	48	AQ569	LCD Display for 46689	73
AQ528	Door Lock Decoration Board, Spray Paint for 46689	24	AQ547	Door Handles-Decorative Covers Spray Paint for 46689	50	AQ570	Magnetron Switch Cover for 46689	74



# Parts Breakdown

## Model DA-CN-0480 46689

Item No.	Description	Position	Item No.	Description	Position	Item No.	Description	Position
AQ571	The Door Frame Reinforcement Plate for 46689	75	AQ575	Add Popular Glass for 46689	79	AQ579	Lower Door Shaft Sleeve for 46689	83
AQ572	The Border of the Door for 46689	76	AQ576	Under-Door Border Decoration for 46689	80	AQ580	Under-Door Frame Reinforcement Plate for 46689	84
AQ573	Left Door Border for 46689	77	AQ577	Door Insulation Cotton for 46689	81	AQ581	Rubber Adjustable Feet for 46689	85
AQ574	Right Door Border for 46689	78	AQ578	The Border under the Door for 46689	82			

# Electrical Schematics

**Model DA-CN-0480** 46689

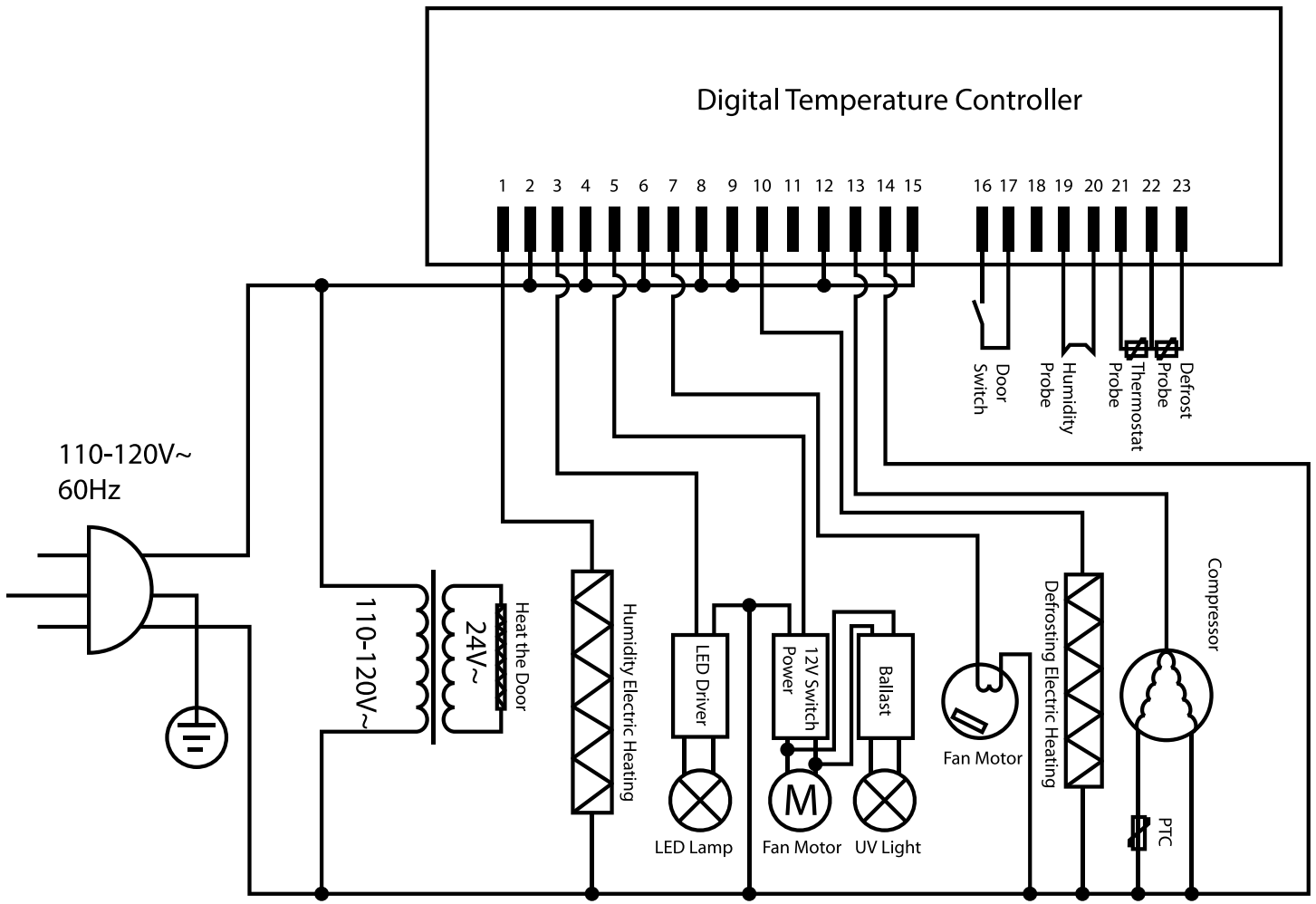

**NEMA**  
 5 - 15P  
 125VAC / 15 AMP



# Warranty Registration

Thank you for purchasing an Omcan product. To register your warranty for this product, complete the information below, tear off the card at the perforation and then send to the address specified below. You can also register online by visiting:

Merci d'avoir acheté un produit Omcan. Pour enregistrer votre garantie pour ce produit, complétez les informations ci-dessous, détachez la carte au niveau de la perforation, puis l'envoyer à l'adresse spécifiée ci-dessous. Vous pouvez également vous inscrire en ligne en visitant:

Gracias por comprar un producto Omcan usted. Para registrar su garantía para este producto, complete la información a continuación, cortar la tarjeta en la perforación y luego enviarlo a la dirección indicada a continuación. También puede registrarse en línea en:

<https://omcan.com/warranty-registration/>

For mailing in Canada

Pour postale au Canada

Por correo en Canadá

For mailing in the US

Pour diffusion aux États-Unis

Por correo en los EE.UU.

**OMCAN**

PRODUCT WARRANTY REGISTRATION

3115 Pepper Mill Court,  
Mississauga, Ontario  
Canada, L5L 4X5

**OMCAN**

PRODUCT WARRANTY REGISTRATION

4450 Witmer Industrial Estates, Unit 4,  
Niagara Falls, New York  
USA, 14305

*or email to: [service@omcan.com](mailto:service@omcan.com)*



Purchaser's Information

Name: \_\_\_\_\_

Company Name: \_\_\_\_\_

Address: \_\_\_\_\_

Telephone: \_\_\_\_\_

City: \_\_\_\_\_ Province or State: \_\_\_\_\_ Postal or Zip: \_\_\_\_\_

Email Address: \_\_\_\_\_

Country: \_\_\_\_\_

Type of Company:

Restaurant  Bakery  Deli

Butcher  Supermarket  Caterer

Institution (*specify*): \_\_\_\_\_

Other (*specify*): \_\_\_\_\_

Dealer from which Purchased: \_\_\_\_\_

Dealer City: \_\_\_\_\_ Dealer Province or State: \_\_\_\_\_

Invoice: \_\_\_\_\_

Model Name: \_\_\_\_\_ Model Number: \_\_\_\_\_

Serial Number: \_\_\_\_\_

Machine Description: \_\_\_\_\_

Date of Purchase (MM/DD/YYYY): \_\_\_\_\_

Date of Installation (MM/DD/YYYY): \_\_\_\_\_

Would you like to extend the warranty?  Yes  No

**Thank you for choosing Omcan | Merci d'avoir choisi Omcan | Gracias por elegir Omcan**



Since 1951 Omcan has grown to become a leading distributor of equipment and supplies to the North American food service industry. Our success over these many years can be attributed to our commitment to strengthen and develop new and existing relationships with our valued customers and manufacturers. Today with partners in North America, Europe, Asia and South America, we continually work to improve and grow the company. We strive to offer customers exceptional value through our qualified local sales and service representatives who provide convenient access to over 6,500 globally sourced products.

---

Depuis 1951 Omcan a grandi pour devenir un des "leaders" de la distribution des équipements et matériel pour l'industrie des services alimentaires en Amérique du Nord. Notre succès au cours de ces nombreuses années peut être attribué à notre engagement à renforcer et à développer de nouvelles et existantes relations avec nos clients et les fabricants de valeur. Aujourd'hui avec des partenaires en Amérique du Nord, Europe, Asie et Amérique du Sud, nous travaillons continuellement à améliorer et développer l'entreprise. Nous nous efforçons d'offrir à nos clients une valeur exceptionnelle grâce à nos ventes locales qualifiées et des représentants de service qui offrent un accès facile à plus de 6500 produits provenant du monde entier.

---

Desde 1951 Omcan ha crecido hasta convertirse en un líder en la distribución de equipos y suministros de alimentos en América del Norte industria de servicios. Nuestro éxito en estos años se puede atribuir a nuestro compromiso de fortalecer y desarrollar nuevas relaciones existentes con nuestros valiosos clientes y fabricantes. Hoy con socios de América del Norte, Europa, Asia y América del Sur, que trabajan continuamente para mejorar y crecer la empresa. Nos esforzamos por ofrecer a nuestros clientes valor excepcional a través de nuestro local de ventas y representantes de los servicios que proporcionan un fácil acceso a más de 6,500 productos con origen a nivel mundial.

